THE BLOCK BRAKING SYSTEM
INSTRUCTION MANUAL

VERSION: A5

DATE: Dec., 2024

Contents

1. Tools	2
2. Installation of the brake	3
3. Adjustment of the stroke.....	4
4. Notice.....	5
5. Installation and debugging of the lever of the brake micro switch	7
6. Manual releasing device	10
7 Remote release device	11
8. Problems and solution of the brake.....	14
9. Maintenance of the brake.....	16

NOTICE!!! Before adjust the braking system should confirm the car s position to prevent strong tip and crouch driver of bottom.

WARNING! When the machine has load, do not adjust the two brakes at the same time.

ATTENTION! When adjusting the braking system, be sure that the one brake has enough braking force, and then adjust the other side.

Safe illustration:

[1] It is forbidden that non-professional persons operate the machine.

[2] Before installation, use and maintenance, read this instruction manual carefully, do as the manual says strictly, to avoid equipment damage or person hurt.

[3] Be cautious when operating, especially the elevator without the machine room, the operator is sure to stand on the safe site.

[4] The manual introduces some components adjustments, it is forbidden to adjust unaccounted components.

Working conditions:

[1] The ambient air temperature should be maintained between 5 and 40 ;

[2] The fluctuation of the supply voltage relative to the nominal voltage of the system should be within $\pm 7\%$;

[3] Ensure that the friction surface is clean and not corroded by oil stains, rain, water, snow, etc.

1. Tools

16# open spanner (two), feeler, cross screwdriver, 21# open spanner, multimeter,

Adjust part 2 guide screw and part 1 installing bolt, make the air gap between part 5 armature and part 4 armature iron is between 0.3~0.55mm, the gap between the braking pad and the braking wheel is between 0.11~0.19mm, the distance between part 2 guide screw and part 4 armature iron surface is 5mm (no less than 3mm under any condition), refer to fig.1.2.

3. Adjustment of the stroke

The air gap of brake corresponds to the gap between the braking pad and braking wheel, so the aim of adjust the air gap of brake is to adjust the gap between the braking pad and the braking wheel.

[1] When the air gap of brake is more than 0.3~0.55mm, please do as follows:

- a) Rotate 4 installing bolts counterclockwise with 21 open spanner until the guide screw can rotate. Refer to fig.1.3.
- b) Rotate 4 guide screws counterclockwise with the 21 open spanner and test the air gap of brake while adjusting until the air gap of brake is between 0.3~0.55mm. Refer to fig.1.4.

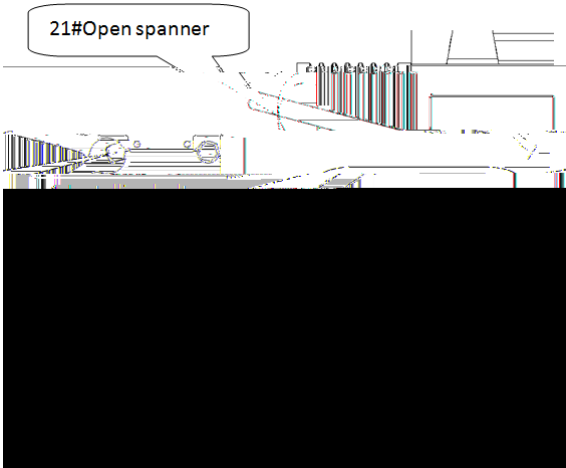

Fig. 1.3

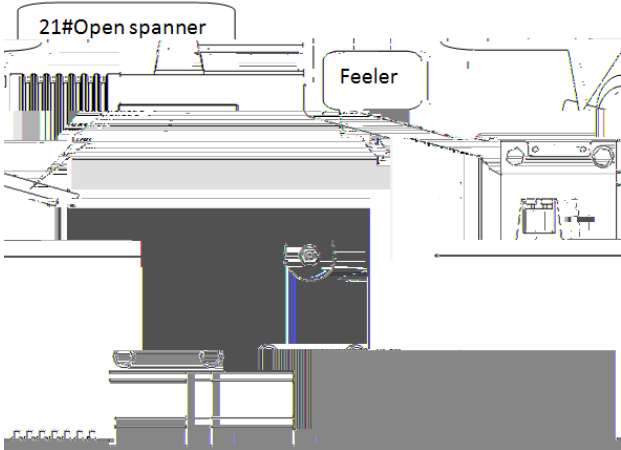

Fig. 1.4

- c) Rotate installing bolts clockwise, fix the brake and the machine base, make

the gap is between 0.30~0.55mm.

d) Rotate 4 guide screws clockwise head to the center of base and make it depend on the base installing surface tightly. Refer to fig.1.5.

e) The adjustment is over, check all the air gap of brake is within 0.3~0.55mm.

If not, please readjust it according to step a ~ d.

[2] When the air gap of brake is less than 0.3~0.55mm, please do as follows:

a) Rotate 4 installing bolts counterclockwise until the 0.3~0.55mm feeler can be put in.

Fig. 1.5

b) Rotate 4 guide screws clockwise head to the center of base and make it depend on the base installing surface tightly. Refer to fig. 1.5.

c) Tighten 4 installing boos 6(m)1953.26 216.86 Tm 0 Tc[(4)] TETBT309.6753.26 216

difference between armature and armature iron evenly as possible.

[2] When the adjustment is over, tighten 4 installing bolts with torque spanner and make the four guide screws depend on the base installing surface tightly. Every bolt and guide screw must be 80N.m lock condition.

[3] When adjusting the bolts, the adjust range must be as small as possible. The air

[6] When the adjustment is over, you should do test to check the braking force (such as the elevator static load test), lock all the adjusting points, make corresponding markers before put into operation.

5. Debugging and precautions of brake micro switch

5.1 Equipped with lever mechanism micro switch adjustment

NOTICE: The brake micro switch is a normally closed switch with a built-in lever mechanism. The triggering stroke and bolts of the micro switch have been adjusted at the factory, and adjustments are strictly prohibited without special reasons. If adjustments are needed, please ensure that the brake is in the braking state before adjusting the micro switch and should be guided by professional personnel, or adjusted strictly according to the prescribed specifications.

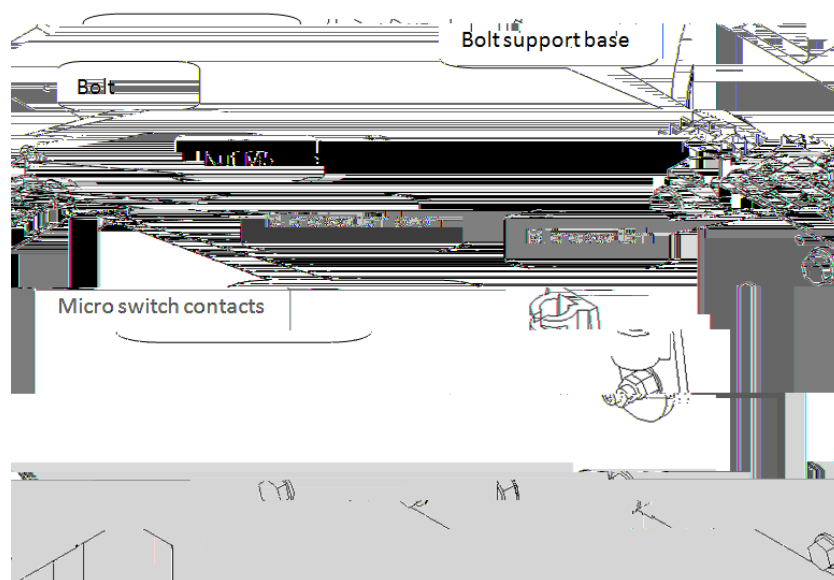

Fig.1.7

[1] Adjustment

After installing the micro switch with its own lever mechanism on the armature, adjust the position of the bolt change the stroke of the microswitch contacts and the end of the microswitch lever to ensure reliable operation of the microswitch.

[2] Problems and solution

- 1) The bolt worn make the lever stroke is not enough and the micro switch does not work.

Loosen the nut M5 of the locking bolt, rotate the bolt, and move it slightly towards the micro switch side. Each adjustment should not exceed 0.1mm, and the maximum stroke of the bolt should not exceed 0.3mm, otherwise the micro switch will not work properly. After adjusting the travel, tighten the nut, power on the brake, and check whether the micro switch operates reliably (repeatedly check 3-4 times). After ensuring that the switch operates reliably, tighten the nut again.

- 2) The bolt stroke is too long and the micro switch can not reset.

Loosen the nut M5 of the top rod bolt, rotate the bolt slightly backwards, then lock the nut M5, power on the brake, check whether the micro switch is reliably operated, and repeat the check 3-4 times to ensure that the micro switch is reliably operated before locking the nut M5.

- 3) The brake switch lever mechanism should be regularly maintained, and special attention should be paid to whether the micro switch lever is in normal working condition.

Installation and debugging of the lever of the brake mhe br3014g3(11co)on 350.93 4cg

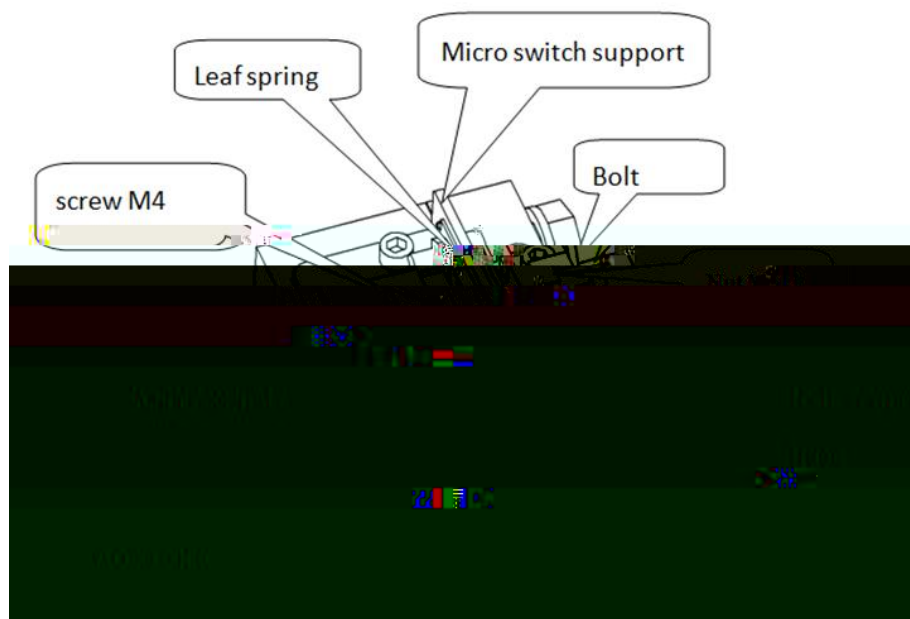

Fig.1.7 a

[1] Adjustment

A micro switch support with a leaf spring and a micro switch is installed on the armature. By adjusting the position of the bolt to change the stroke in order to ensure the micro switch working reliably.

[2] Problems and solution

- 1) The bolt worn make the lever stroke is not enough and the micro switch does not work.

Loosen the nut M5, rotate the bolt towards the leaf spring a little, each adjustment should less than 0.1mm, or the leaf spring will be deformed. The Bolt should less than 0.5mm, or the micro switch cannot work properly. After the stroke is adjusted, The Nut M5 is tightened, Connect the brake to the power and check whether the stroke switch is reliable check 3-4 times make sure that the micro switch is useful, then lock the nut M5.

- 2) The bolt stroke is too long and the micro switch can not reset.

Loosen the nut M5, rotate the bolt backwards, then lock the nut M5. Connect the brake to the power, check if the micro switch is useful, check

3-4 times, make sure that the micro switch is useful, then lock the nut M5.

3) The brake lever device must be regular maintenance every year, especially the state of leaf spring, deal with timely if there is any problem.

6. Manual releasing device

When there are problems while the elevator running or the persons are kept in the car for the power off, you may use manual releasing device to operate.

NOTICE: The manual releasing device should be operated by 2 professionals, and make sure the power is shut down first.

Method to use the manual releasing device:

[1] One person use spanner of carrying machine respectively inserted into the left and right brake keyway and then rotary spanner. Make the pin on the spanner is just placed on the keyway To prevent the spanner slipping when manual releasing device . Then rotate and move spanner with force, the brake can be opened

[2] The steps of operation at the same time, another person take the handwheel down from the wall, fix the small gear on the machine, make the small gear engage with the big gear, rotate the handwheel to make the car move slowly.

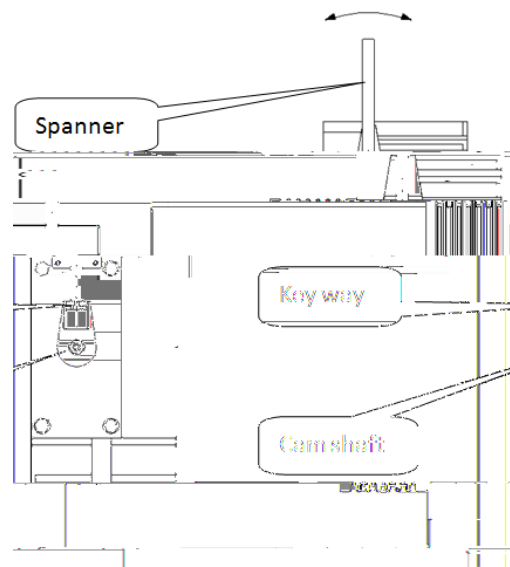

Fig.1.8

7 Remote release device

When the elevator is installed without the machine room, it is necessary to use the remote release device for emergency operation when the elevator is in the process of operation, or because of power failure caused by the situation.

Note: The handle should be installed in a safe location, can only be operated by professional personnel, ensure the operation cut off the main power supply, to strictly prevent the brake opened causes the elevator to slip danger.

When installing a remote release device, the brake shall not be adjusted without permission;

Remote release device has been adjusted, no special circumstances do not adjustment hav(e)-sixed on the brake device of the machine.

[1]Remote release device and the main parts

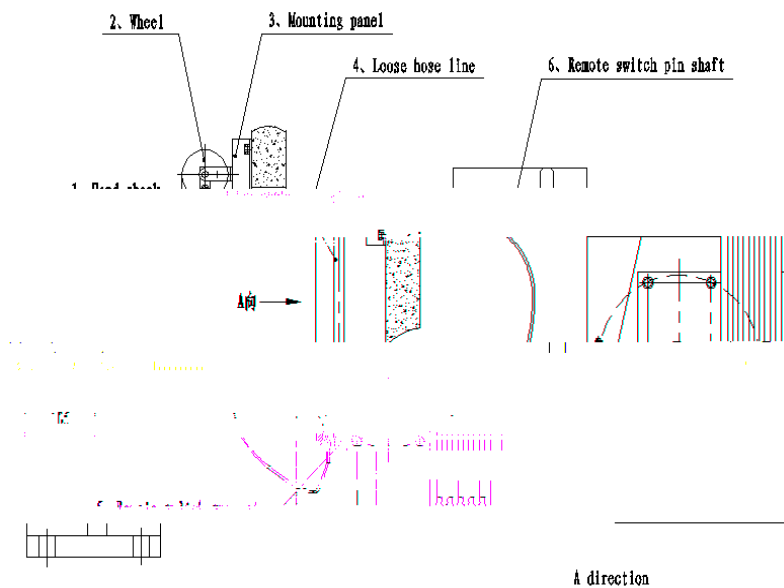

Fig.1.9

[2]The remote release device profile

Fig.1.10

[3]The installation of remote release device

1)The two loose hose lines 4 are respectively passed through the traverse holes of the

2)The other end of the two loose hose lines 4 is passed through the remote switch bracket 5, which has been fixed on the brake, and the remote switch pin shaft 6 is inserted into the cam mounting hole of the brake and rotates 45 degrees, the long distance opening pin shaft 6 is inserted into the cam mounting hole of the brake, and the long distance switch pin shaft 6 is inserted into the cam mounting hole of the brake. Prevent remote opening pin shaft from falling off, then use locking nut to pre-tighten the

causing the running of the car, etc.

[5] The use of remote brake device

- 1) Take down the safety bolt M6*35 of the serial number 9, and raise two handle 1 at the same time. The handle 1 rotates about 105 degrees and two brakes will open, when the sluice is loosened, the speed of the car and the flat layer of the car will

through the air gap between the braking pad and the braking wheel.

2) Solution

- a) Check if the guide screw depend on the machine base surface tightly. If not, please rotate the guide screw clockwise by 21# open spanner and make it depend on the base surface tightly. Refer to fig.1.5.
- b) If the guide screw has already depend on the machine base surface tightly, please loosen the four installing bolts counterclockwise, then rotate the guide screw clockwise and make it depend on the machine base surface tightly, at last, lock the four installing bolts with torque spanner. Refer to fig.1.5.

[2] B work

- a) Low input voltage. Check if the input voltage exceeds the 80% of the rated voltage. If not, increase the input voltage properly.
- b) The air gap of the brake is more than 0.55mm. If it is, adjust it as Described above.

[3] Brake noise exceeding standard

1 The noise of brake opening exceeds the standard. The countermeasures are as follows:

(a) check whether the air gap of the brake is within the prescribed range of 0.3 -0.55 mm and, if it is out of range, adjust the air gap in accordance with the preceding "three air gap adjustments";

b if the shock absorber is seriously worn and flush with the armature suction surface, contact the brake manufacturer for replacement if the wear is severe.

2) the noise released by brake exceeds the standard

This situation is mainly due to the larger gap between the brake belt and the brake wheel. According to the contents of "3. air gap adjustment" in front of the brake, the air gap of the brake is adjusted, and the gap between the brake belt and the brake wheel is reduced. The noise released by brake can be reduced (gap between

brake belt and brake wheel requires 0.11~0.19mm).

[4] Micro switch trigger fault

According to the previous content "5. brake micro switch installation and debugging and matters needing attention" in article 2 of the explanation.

9. Maintenance of the brake

When the braking pad has a little worn, it would add the brake air gap and make the braking noise much bigger. You may adjust it .When there is much worn of it, the brake would not work. When its thickness is less than 5mm, replace it.

NOTICE! The static load test method: add 150% rated load in the car, observe the braking wheel for ten minutes, there should have no skid between the braking wheel and the braking pad.

WARNING! If the braking force test is unqualified, then the elevator is forbidden to be electrified, otherwise it would occur accidents.